



Il montaggio del prodotto deve essere eseguito da personale specializzato. *The mounting of the product it must be realized from staff specialist*

Questo prodotto potrebbe non essere conforme al codice stradale o alle leggi vigenti in alcuni paesi e quindi utilizzabili solo in aree private e/o chiuse al traffico

This product may not comply with local road rules and regulations and can be used only in private areas and/or areas closed to traffic.

LEGENDA / LEGEND



Bloccare con frenafilletti: L= Leggera - M= Media - S= Forte
Lock with the threadlocker: L= Light - M= Medium - S= Strong



Parte della dotazione originale
Original equipment manufacturer's part

OEM

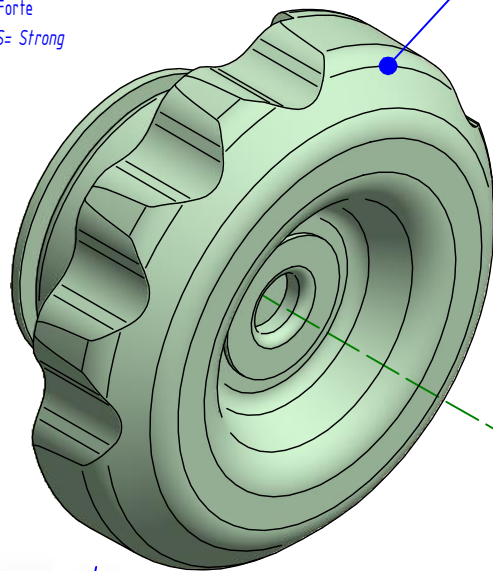

NOTA: PER ESTRARRE IL PEZZO DAL TAPPO ORIGINALE UTILIZZARE UNA VITE M5 LUNGA ABBASTANZA (NON FORNITA)

NOTE: TO REMOVE THE PART FROM THE OEM CAP USE A M5 SCREW LONG ENOUGH (NOT SUPPLIED)

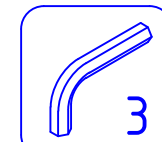
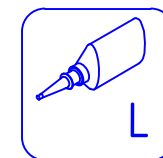

M5x8

